

Specifications

Output Power HP (kW)	2 (1.5)
Phase	3 Phase
Pole	6 Pole
Frame Number	100L

Degrees of Protection	IP 55
Enclosure Construction	Totally-enclosed Fan-cooled
Thermal Class	Class F (155 °C)

Alignment	Vertical
Frame Material	Steel plate

Power Transmission	Direct-couple or Belt Driven
Direction of Rotation	Counterclockwise (CCW) viewed from shaft-end side

Connection Type	Terminal Block (6 Leads)
Coating Colour	Munsell N5.5 (Gray)
Conformed Standard	IEC 60034-1 & JEC-2137-2000

Voltage & Frequency	LT Type
	220/380~415V 50Hz 220/440V 60Hz

Motor Characteristics

Type	Hz	V	50% Load			75% Load			100% Load				Torque(%)		Is (A)	Inertia GD ² (kg-m ²)	
			(A)	Eff(%)	PF(%)	(A)	Eff(%)	PF(%)	(A)	Eff(%)	PF(%)	Speed (r/min)	Torque (kg-m)	Ts			Tm
LT	50	220	4.52	0.78	0.56	5.40	0.81	0.68	6.55	0.81	0.74	930	1.57	245	244	35.5	0.033
		380	2.61	0.78	0.56	3.12	0.81	0.68	3.78	0.81	0.74	930	1.57	245	244	20.5	
		415	2.79	0.77	0.48	3.17	0.82	0.60	3.69	0.84	0.67	940	1.55	292	291	22.4	
	60	220	3.93	0.80	0.63	4.92	0.82	0.73	6.19	0.82	0.78	1110	1.32	198	206	28.8	
		440	2.46	0.76	0.53	2.86	0.81	0.64	3.38	0.82	0.71	1120	1.30	264	280	19.8	

Dimensions (mm)

Flange Number	Motor								
	D	IE	LA	LB	LC	LE	LG	LL	LZ
FF215	207	130	215	180 j6	250	4	16	321	14.5

Terminal Box			Shaft End						
KD	KG	KL	LR	Q	QK	S	T	U	W
PF 3/4	148	169	60	60	45	28 j6	7	4	8

Bearing No.		Approximated Weight (kg)	Approximated Packing Dimensions (LxWxH)	Gross Weight (kg)
Drive End	Opposite			
6206ZZ	6205ZZ	29	456 x 355 x 300	31.5

Connection & Connection Diagram

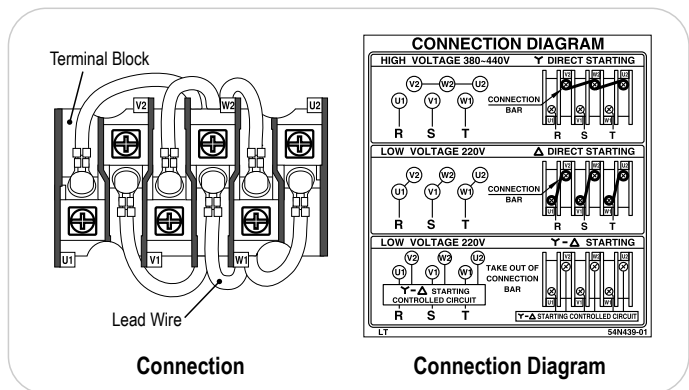

Circumstance Conditions

Ambient Temperature	-20 ~ +40°C
Ambient Humidity	95% RH or less
Operating Altitude	Less than 1,000m above sea level
Environment	No bursting / erosive gas or vapor